

Original BMW Parts and Accessories. Installation Instructions.



M Performance Carbon Roof Panel Retrofit Kit. BMW M2 (F87)

Retrofit kit number

41 31 2 460 277 Carbon roof panel

Installation time

The installation time is **approx. 12.5 hours**. This may vary depending on the condition of the car and its equipment package.

The installation time shown does not include any time spent on programming/coding.

The calculation of the total costs for the programming time must be factored into the calculation of retrofitting costs (must not be invoiced under the warranty).

Important information

 **We recommend that the retrofitting work is carried out by a body shop which has experience in replacing damaged carbon roofs. ◀**

Furthermore, these installation instructions are primarily designed for use within the BMW dealership organisation and for authorised BMW service companies.

These installation instructions are intended for use by qualified specialist staff trained on BMW cars with the relevant expert knowledge.

All work must be completed using the latest BMW repair manuals, wiring diagrams, servicing manuals and work instructions, in a logical order, using the prescribed tools (special tools), and observing current health and safety regulations.

 An amended registration document must be requested at the start of the work using the email address **parts-and-accessories@bmw.de** for cars with a sunroof **(SA 403)**. ◀

If you experience installation or functional problems, restrict troubleshooting to approx. 0.5 hours for mechanical work and 1.0 hour for electrical work.

To avoid unnecessary extra work and/or costs, send an inquiry straight away to the technical parts support team via the Aftersales Assistance Portal (ASAP).

Quote the following information:

- VIN,
- retrofit kit part number,
- a detailed description of the problem,
- any work already carried out.

Do not archive the hard copy of these installation instructions, since daily updates are supplied in ASAP.

Pictograms

 Denotes instructions that draw your attention to dangers.

 Denotes instructions that draw your attention to special features.

◀ Denotes the end of the instruction or other text.

Installation information

- All contact/bonding surfaces on the components being installed must be absolutely dry, clean, and free of wax, silicone and grease. These surfaces must be treated with suitable BMW cleaner or BMW primer (see EPC for details), as set out in the appropriate product application instructions
- If you use adhesive tape, it must be applied using a contact pressure of between 10 N/cm² and 50 N/cm²
- Take care not to damage the parts when opening the packaging
- Check that all the parts fit accurately on the car before fitting them
- All the components and their bonding surfaces must be at room temperature for installation. The ideal relative humidity is 50%. Different values will change the specified times
- After completing the bonding and installation work, the car must remain stationary at room temperature for at least **12 hours**
- If adhesives are used, the car may be driven after **24 hours**, and may be taken through a car wash after **48 hours**. The car must not be driven above a speed of $v_{\max} < 100$ km/h for 24-48 hours
- The installed parts may become loose and fly off the car if you fail to wait for the full reaction time of the primer/adhesive. **Danger of accidents!**
- Some of the installation steps are shown only on one side of the car. Proceed in the same way on the other side of the car
- All pictures show LHD (left-hand drive) cars; proceed accordingly on RHD (right-hand drive) cars

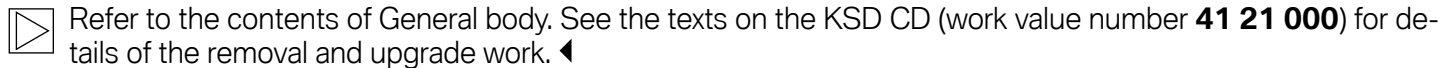
 Refer to the contents of General body. See the texts on the KSD CD (work value number **41 21 000**) for details of the removal and upgrade work. ◀

Ordering instructions

The materials such as liquid adhesives, cleaners and activators are assigned to the relevant products in the EPC (see EPC for information and part numbers). If the EPC does not explicitly specify any materials, always use cleaner, adhesive and activator from the BMW product range.

Special tools required

Cartridge press (Part No. 81 49 0 443 166)

Pliers set (Part No. 83 30 0 496 315)

Table of contents

Section	Page
1. Carbon roof panel parts list	4
2. Preparatory work	5
3. Carbon roof panel installation	6
4. Removing the steel roof and preparing for bonding	7
5. Aligning the carbon roof panel	9
6. Carbon roof panel bonding	10
7. Sealing the roof frame and installation clips for roof decor strip	12
8. Concluding work and coding	14

1. Carbon roof panel parts list

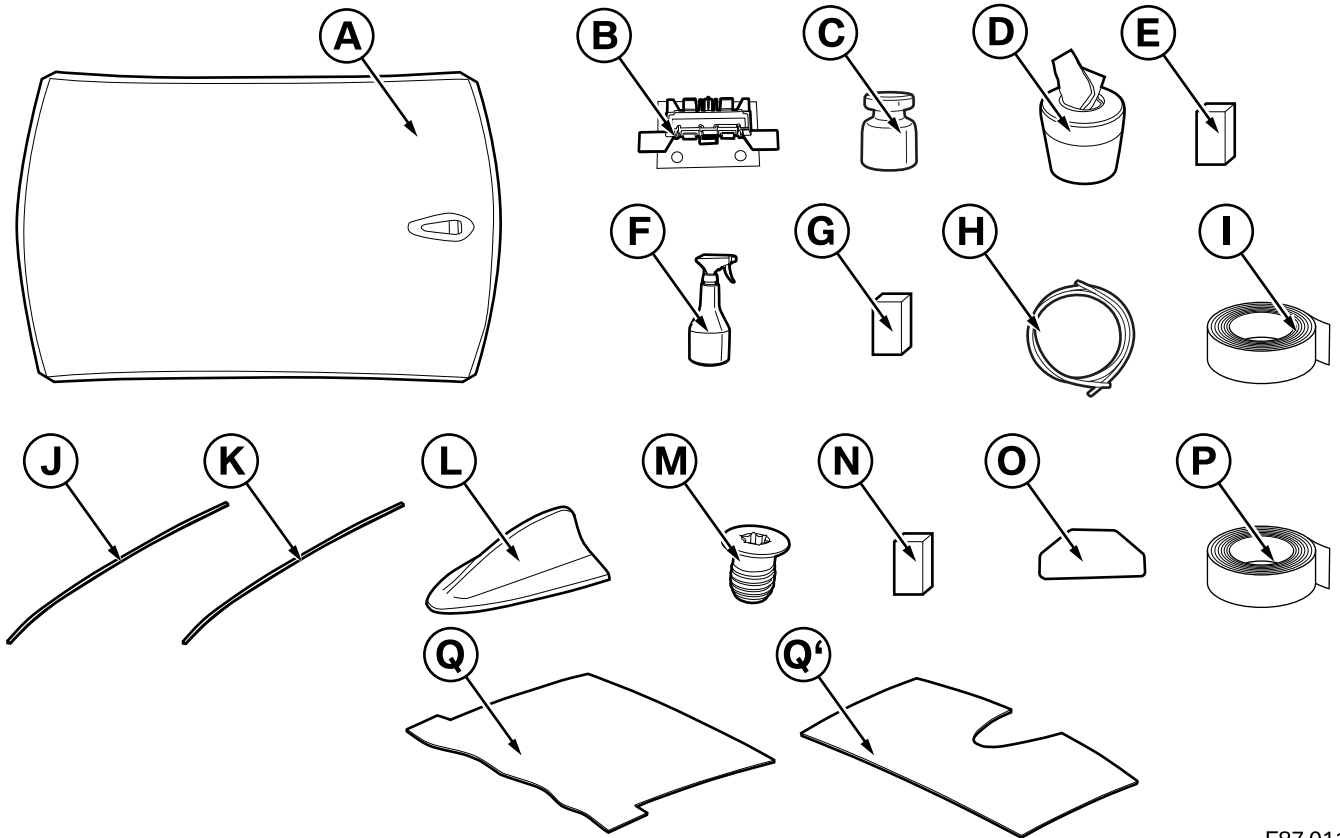

F87 0115 V

Legend

A Carbon roof panel

Not included in kit, see EPC for details

- B** Clip for roof decor strip (12 x, Part No. 51 13 8 060 761)
- C** Sika activator 205 (Part No. 83 19 0 030 155)
- D** ScotchBrite Multiflex (Part No. 51 91 0 402 967)
- E** K3 bodywork adhesive (Part No. 83 19 0 417 144)
- F** R1 cleaner (Part No. 83 19 2 211 217)
- G** Windscreen adhesive, cold, 1 hour (Part No. 83 19 2 289 286)
- H** Windscreen cover, top (Part No. 51 31 7 240 671)
- I** Yellow adhesive tape (Part No. 83 19 9 410 979)
- J** Roof décor strip, primed, left (Part No. 51 13 7 341 749)
- K** Roof décor strip, primed, right (Part No. 51 13 7 341 750)
- L** Roof antenna empty housing, primed (Part No. 65 00 9 259 440)
- M** Screw plug (4 x, Part No. 07 14 8 065 005)
- N** Liquid adhesive K1 (Part No. 83 19 0 413 015)
- O** Eye guard (2 x, Part No. 51 31 8 064 285)
- P** Adhesive tape
- Q** Roof sound insulation, front (Part No. 51 48 7 300 038)
- Q'** Roof sound insulation, rear (Part No. 51 48 7 300 133)

For modifying a sunroof only, see EPC for further details

- R** Roof bow (Part No. 41 32 7 342 107)
- S** Headlining (see EPC for details and part numbers)
- T** Roof function centre (see EPC for details and part numbers)

2. Preparatory work

The following components must be removed first of all	ISTA/AIR No.
Disconnect the battery	61 20 900
A pillar trim	---
B pillar trim	---
C pillar trim	---
Headrest for rear seat	52 26 210
Trim for rear window shelf	51 44 001
Roof lining	51 44 001
Windscreen	51 31 000
Rear window	51 31 200
Roof décor strip, left and right	51 13 280
Roof antenna	65 20 035

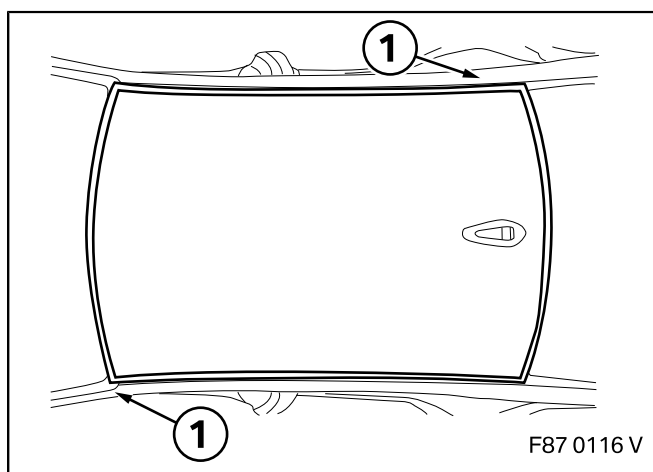

▶ Protect the interior of the car from chips, particularly the window shafts and rear seat.

Affix the roof frame (1) with suitable adhesive tape to protect it from scratches. ◀

3. Carbon roof panel installation

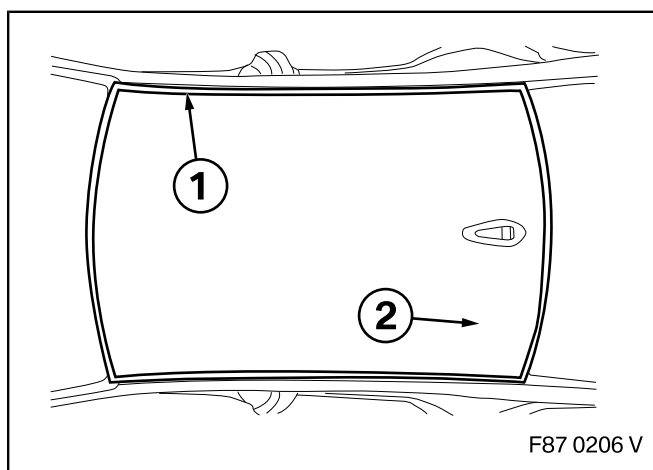

Release the welds (1) on the steel roof panel (2) using suitable equipment, for example expose them by grinding and release them by drilling.

⚠ Do not drill through the complete body. If additional welds have been destroyed, they must be rewelded. ◀

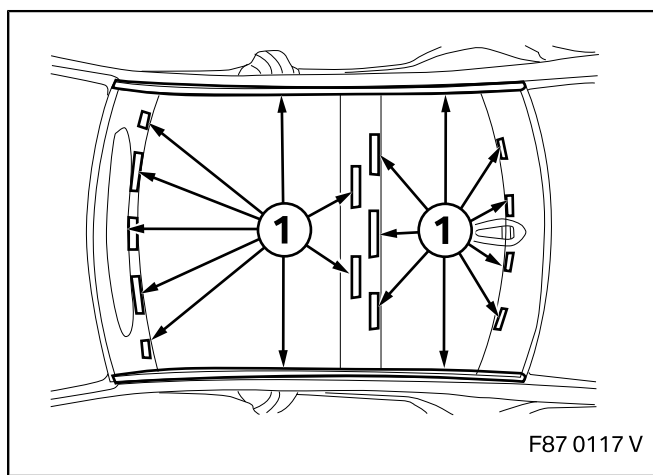

Cut the adhesive joints in the inner lining in the areas (1) from the interior of the car using suitable equipment (for example a long blade).

4. Removing the steel roof and preparing for bonding

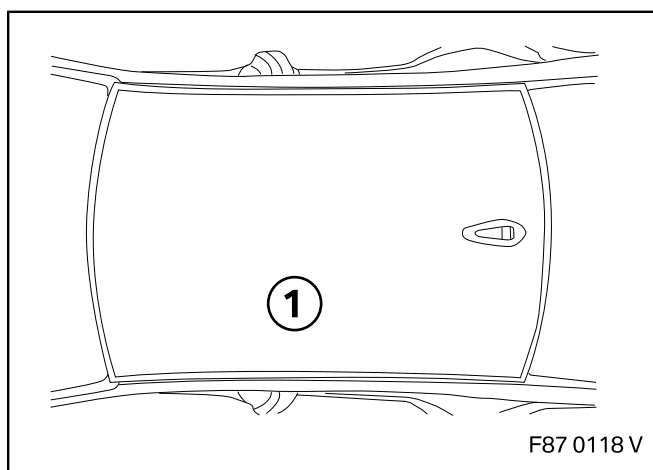

Remove the steel roof panel (1) as described in the repair instructions in ISTA/AIR No. **41 31 000**.

▶ The next steps must be carried out immediately after the steel roof panel (1) has been removed to prevent rust formation. ◀

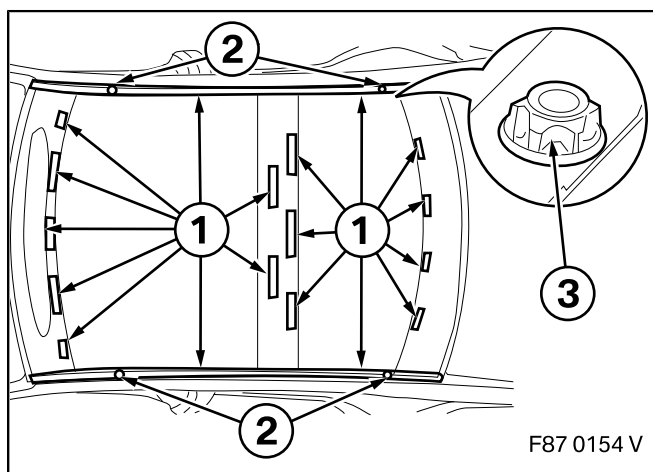

Remove the adhesive at the positions (1) using suitable equipment.

Remove the threaded blocks (2) and keep them safe.

Remove the star screws with an internal thread (3).

⚠ The star screws with an internal thread must not be reused as the carbon roof panel **A** cannot be used with roof racks. ◀

Grind the drilled welds using suitable equipment.

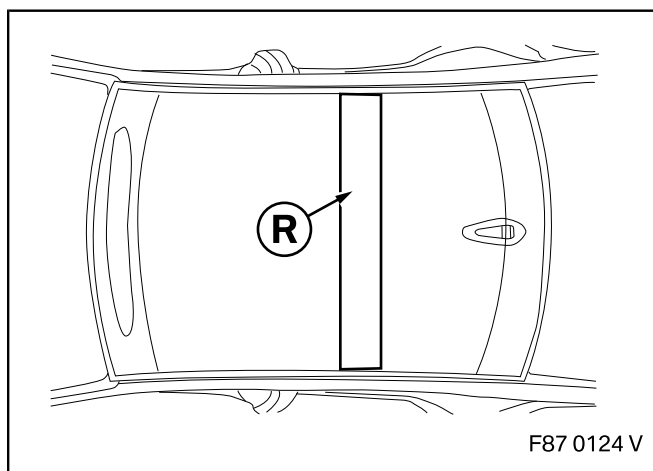

Cars with a sunroof

▶ Cover the interior, particularly the rear seat, using suitable equipment. ◀

Retrofit the roof bow **R** as described in **ISTA/AIR**.

4. Removing the steel roof and preparing for bonding

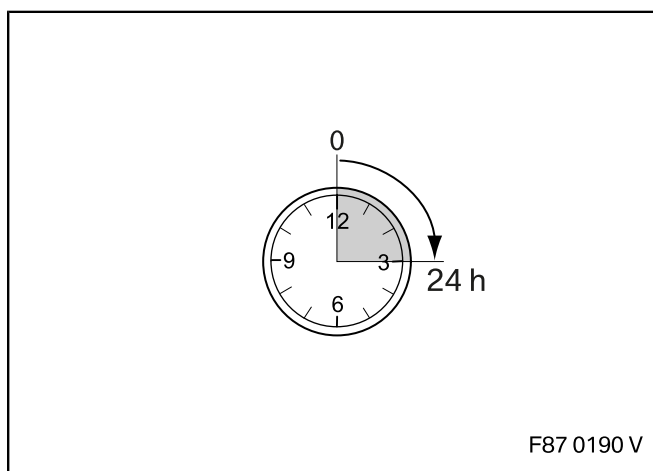
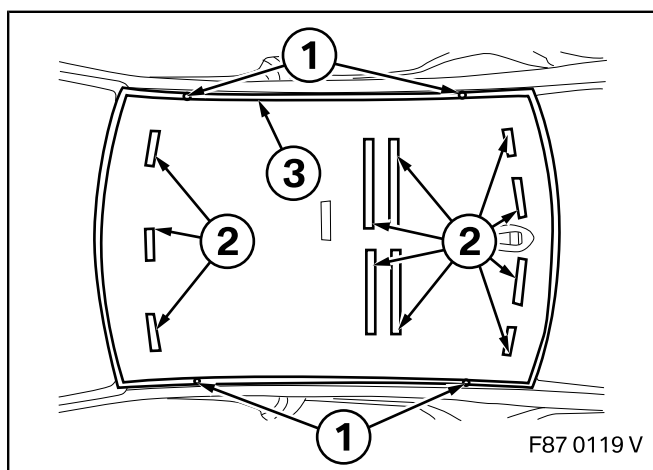

- ☐ Completely remove the PVC residues around the roof frame since otherwise the clips to secure the roof decor strip (see Figure **F87 0126 V**) cannot be bonded into position correctly. Carry out a visual inspection. ◀

Any damage to the primer caused as shown in graphic **F87 0154 V** must be treated as follows to maintain perfect corrosion protection.

Clean with R1 cleaner.

Apply a uniform, thin coating of adhesive K1 to the bare metal areas using a plastic spatula.

- ☐ As you apply adhesive K1, ensure that the bore-holes (1) remain clear so that the screw plugs (M) can be installed in them later. ◀
- ☐ The next step must not be carried out for **24 hours**. ◀

5. Aligning the carbon roof panel

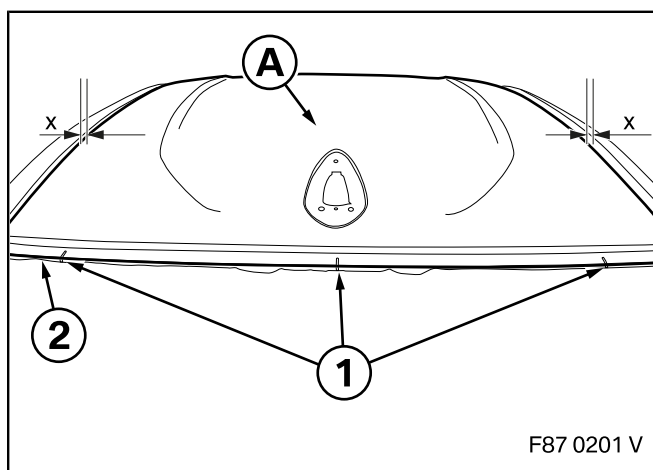

Check the space for the later installation of the clips for installing the roof decor strips

- ▶ Check the gaps at the right and left using suitable measuring equipment. It must be identical on both sides of the car. The later positioning of the clips is important to ensure the gaps for the roof decor strips are uniform (see graphic F87 0126 V). ◀

Position the carbon roof panel **A** and make a mark (1) at the position on the carbon roof panel **A** and on the roof bow (2) using suitable equipment in an area which will not be visible later.

Repeat this at the front.

6. Carbon roof panel bonding

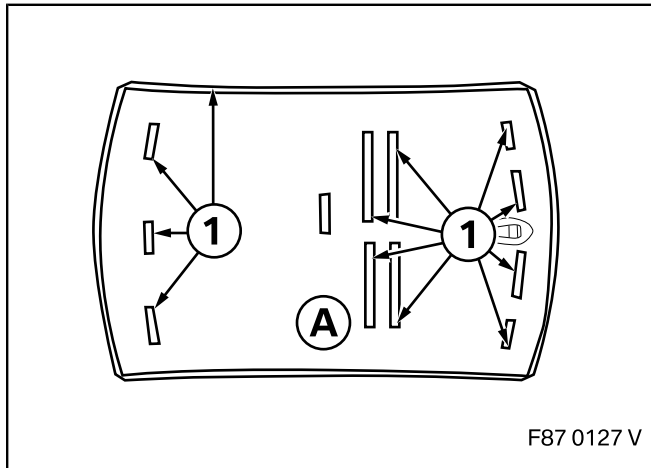

Prepare the bonding flanges (1) on the carbon roof panel **A**.

Roughen them using a Scotchbrite Multiflex **D** abrasive pad.

Clean with R2 cleaner.

Mask the roof frame up to the level of the carbon roof panel **A**.

Clean all the areas (2) and (3) on the car which come into contact with adhesive, using R1 cleaner **F** as shown in graphic **F87 0119 V**.

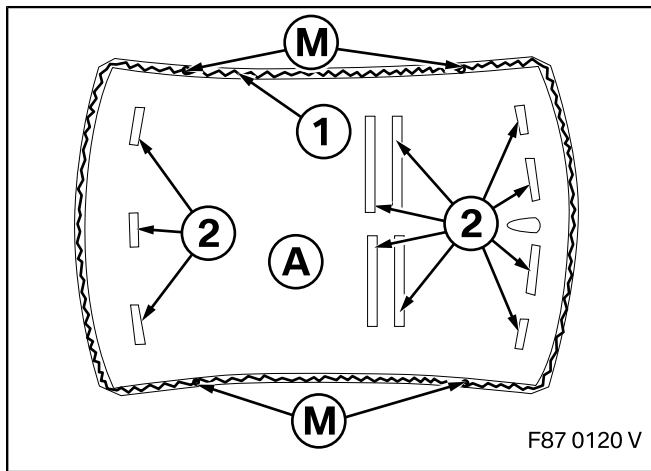

Apply body adhesive **E** in the area (1) around the carbon roof panel **A** in a triangular shape.

Apply windscreen adhesive **G** in area (2) in a triangular shape on the car. Align the carbon roof panel **A** using the marks on the roof and secure it with screw plugs **M**. Seal the screw plug heads with body adhesive **E** to prevent corrosion.

Check again whether the clips can be inserted into the roof frame.

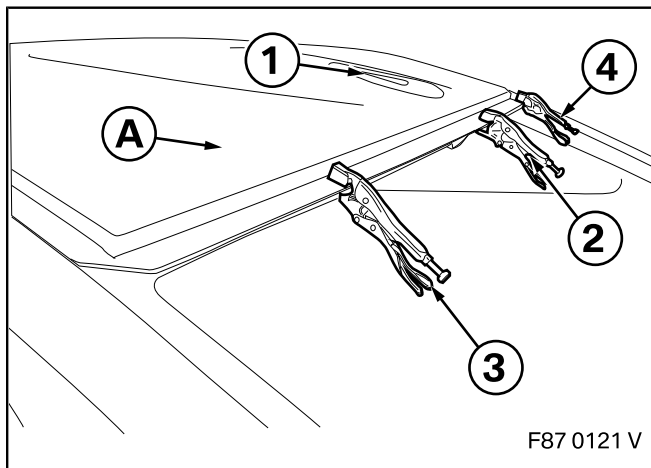

Secure the carbon roof panel using pliers

▶ The pliers set (Part No. 83 30 0 496 315) must be used for the following work. The tools used here are part of the pliers set.

Ensure that when you fit the pliers, you do not use excessive force since otherwise you may damage the clearcoat finish.

We recommend that you fit to additional pliers at the front and rear uniformly spaced. ◀

Start on the rear window. Fit the first locking pliers (2) **(41 3 201)** in the centre level with the roof antenna opening (1). Then fit the other locking pliers (3) and (4) **(41 3 201)** towards the outside.

Repeat this process on the side of the windscreen.

6. Carbon roof panel bonding

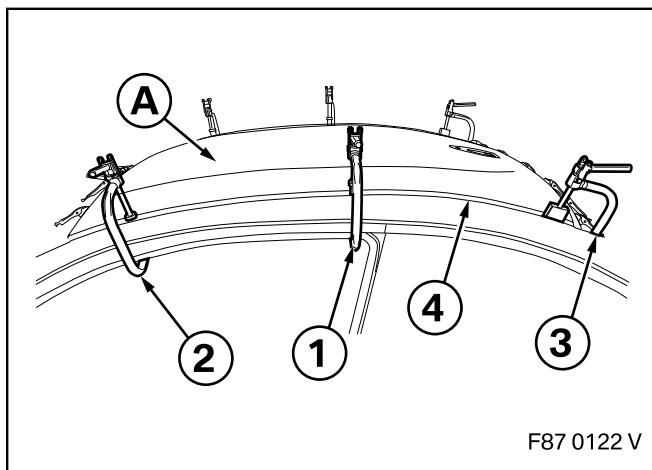

Start in the centre of the B pillar with screw clamps (1) **(41 3 202/204)**.

Secure the screw clamps (2) and (3) **(41 3 202/203)** in sequence to the A and C pillars in the gutter (4).

Repeat this work on the opposite side.

☐ Completely remove any excess adhesive emitted onto the adhesive joint while securing the carbon roof panel. ◀

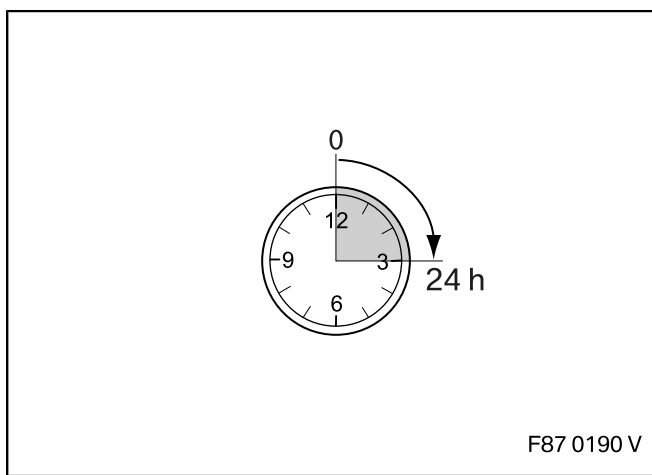

☐ The next step must not be carried out for **24 hours**. ◀

Remove the pliers once the adhesive has cured. Check for any paintwork damage in the masked area of the roof frame and replace the adhesive masking.

Apply the roof sound insulation for the front **Q** and rear **Q'** in the same way as for the standard roof panel.

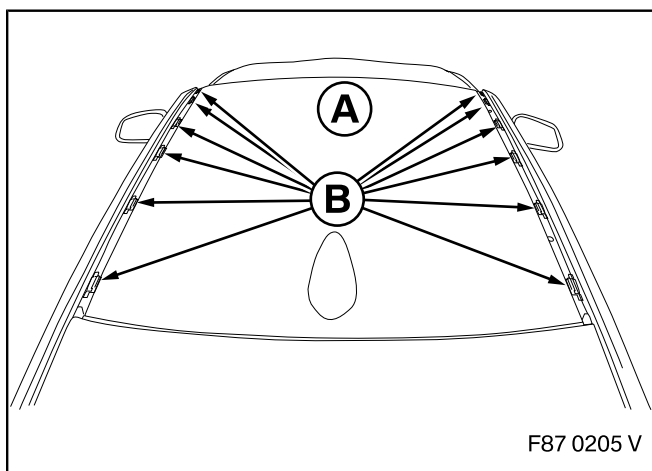

Prepare the bonding surfaces for clips

☐ The bonding surfaces must be completely dry, clean, and free from wax or grease. ◀

Prime the bonding surface in the embossed areas of the roof before bonding with Sika Activator 205 **C**. Wait for the flash-off time.

7. Sealing the roof frame and installation clips for roof decor strip

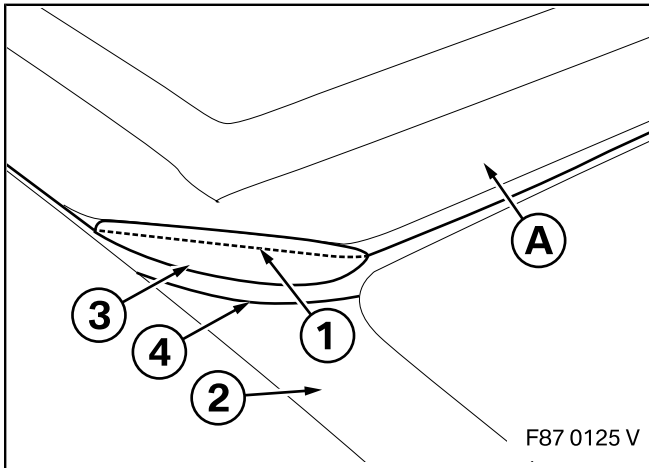

Smooth the step (1) between the carbon roof panel **A** and A pillar (2) with an additional bead of adhesive, but do not apply it beyond the standard bead (4).

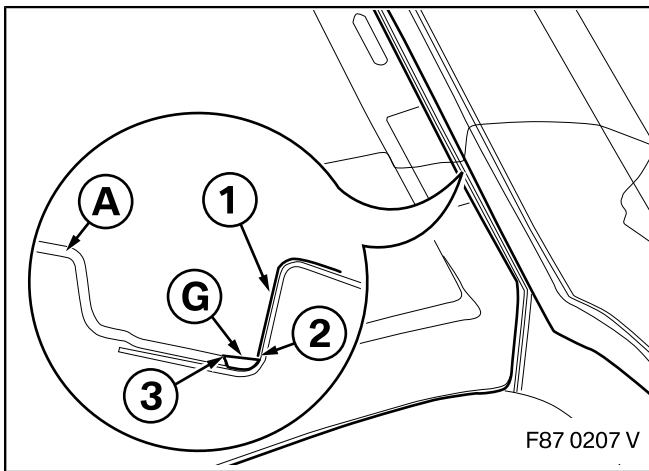

▢ The next steps are required to seal the paintwork damage on the side frame brackets (roof gutter) created when removing the steel roof to prevent corrosion. ◀

Check the masking (1) to ensure that the end (2) finishes at the radius of the fillet joint.

First apply a bead of windscreen adhesive **G** on the vehicle side and coat the fillet joint between the end of the masking (2) and the edge of the carbon roof panel (3) so that any paintwork damage is covered.

Remove the masking (1) in the bonding area.

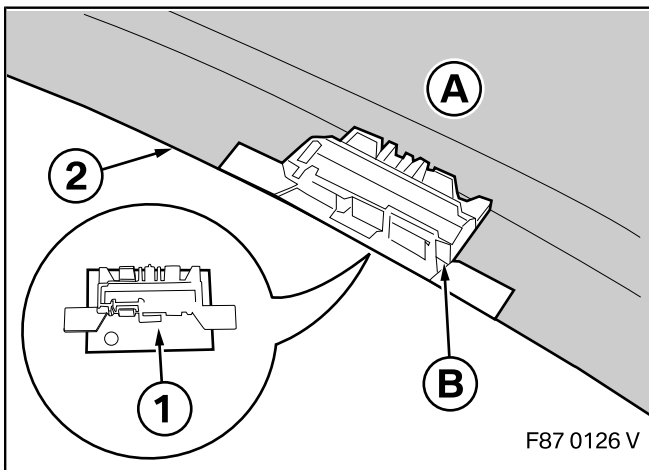

Before the curing process starts, glue the six clips onto the freshly sealed roof side in the embossed areas provided for them. The legs of the clips must be flush with the side frame (pressed them into the soft sealing compound if necessary) to make the joints of the roof decor strip appear uniform.

Obey the following instructions for gluing the clips:

Remove the adhesive protection (1) from the clip for the roof decor strip **B**. Place the clip for the roof decor strip **B** with the wide side on the contour (2) of the roof and affix it firmly to the troughs on the carbon roof panel **A**.

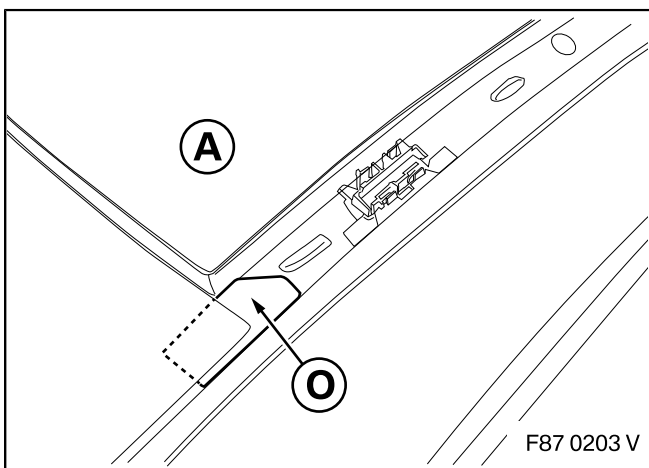



Bond the eye guard **O** as shown on the reverse.

▢ The illustration shows the eye guard in its later position, partly beneath the rear window. ◀

Repeat the process on the opposite side.

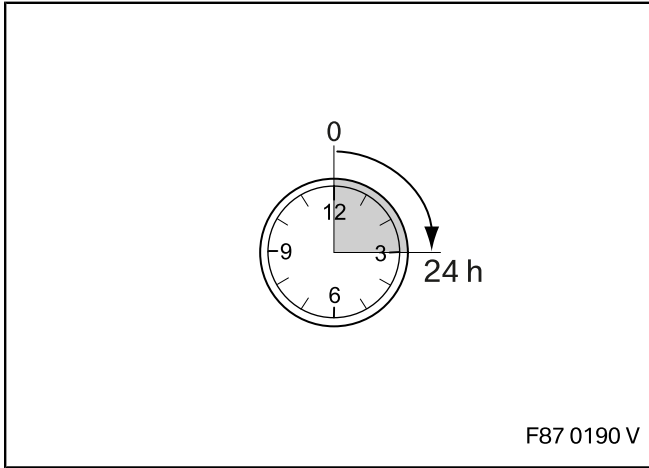
7. Sealing the roof frame and installation clips for roof decor strip



 The next step must not be carried out for **24 hours.** ◀

8. Concluding work and coding

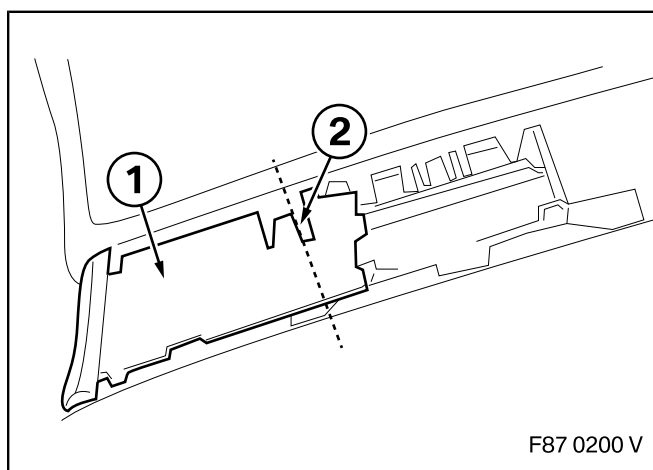

Pull off the front end pieces (1) from the roof decor strip and cut them on the line (2) using suitable tools.

Then reconnect them.

Check that they are secure and fix them with adhesive if necessary.

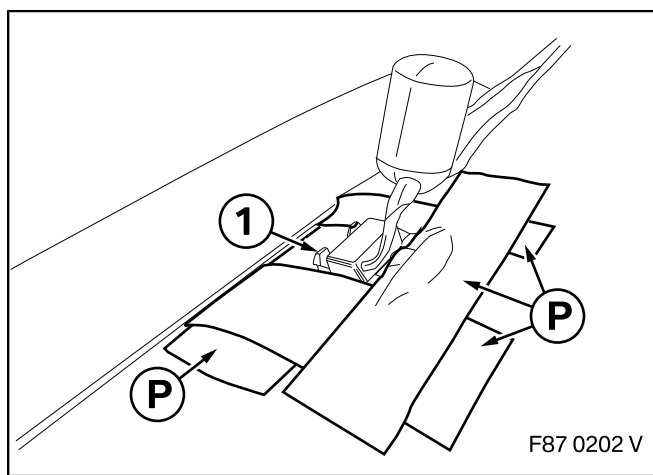

Before bonding the windscreen and rear window, the microphone trim (1) must be reinforced from the inside with adhesive tape **P** as shown as you install the headlining.

- Re-assemble the car
- Connect the battery
- After the modification, an amended registration document requested using email address **parts-and-accessories@bmw.de** must be flashed onto cars with a sunroof (**SA 403**)
- Conduct a function test
- Refer to the downtimes of the car in the installation information on page 2