

**Sport Exhaust System, 3.8 l (I-no. 176)**



**Information**

- The help of another person is required for removing and reinstalling the muffler.

Revision: This bulletin replaces bulletin Group 2, #27/12, dated November 2, 2012.

Model Year: **As of 2012 up to 2016**

Information: **Retrofitting**

Engine type: **MA1.03 (3.8 l)**

Restriction: **Not** approved for vehicles with Power Kit (I-no. X51).



Notes: The sports exhaust system is activated and deactivated using the new switch console with the additional "Twin tailpipe" button. The sports exhaust system is also activated by pressing the "Sport" and "Sport Plus" buttons. The sports exhaust system can be switched off separately in these modes using the "Twin tailpipe" button.

The strip for switches must also be ordered. The switch console is modular and must be assembled in accordance with the new vehicle equipment.

On the 3.8-liter engine, a change-over valve, which is installed as standard, is used for controlling the sports exhaust system.

Engine power and exhaust behaviour of the vehicle are not affected.

Parts Info: **991.044.200.06**

⇒ Sports exhaust system, 3.8 l, set

**Information**

Activate the VIN filter in the PET in order to quickly identify the combined switch (switch console).

Also order the following in accordance with vehicle equipment:

<b>991.613.955.03 DML</b>	Combined switch (switch console), I-no. 652, Coupé
<b>991.613.957.03 DML</b>	Combined switch (switch console), I-no. 653, Coupé
<b>991.613.959.03 DML</b>	Combined switch (switch console), I-no. 651, Coupé
<b>991.613.967.03 DML</b>	Combined switch (switch console), I-no. 552, Cabriolet
<b>991.613.963.07 DML</b>	Combined switch (switch console), Targa

Parts List:



Figure 2

991.111.437.07	1 x	Front muffler ⇒ Figure 2-1-
991.111.325.01 <sup>1</sup>	1 x	Main muffler, left ⇒ Figure 2-2-
991.111.326.01 <sup>1</sup>	1 x	Main muffler, right ⇒ Figure 2-3-
991.111.492.00	2 x	Vacuum line, 190 mm (steel flexi-pipe) ⇒ Figure 2-4-
991.111.465.03	1 x	Tailpipe cover, left ⇒ Figure 2-5-
991.111.466.03	1 x	Tailpipe cover, right ⇒ Figure 2-6-
997.111.520.00	2 x	Clamping sleeve ⇒ Figure 2-7-
991.111.482.00	2 x	Seal ⇒ Figure 2-8-
991.111.481.01	2 x	Restraining straps ⇒ Figure 2-9-
900.910.003.03	6 x	Hexagon nut, M8 (three-hole flange, not shown)
900.918.005.40	1 x	Tekalan line, 5.0 x 1.0 x 1,000 mm ⇒ Figure 2-10-

991.111.491.00	1 x	Vacuum line, 80 mm (steel flexi-pipe) ⇒ <i>Figure 2-11-</i>
991.111.488.00	1 x	Holder ⇒ <i>Figure 2-12-</i>
999.651.401.01	1 x	Fixing clip on engine carrier (not shown)
— — —	8 x	Collar nuts, M8 (strut) ⇒ <i>Figure 2-13-</i>

<sup>1</sup> **Only** contained in set 991.044.200.07.

Materials:

000.043.204.82	1 x	Adhesive compound
000.043.004.82	1 x	Optimol-HT mounting paste
— — —		Rust solvent, commercially available, e.g. WD40

Notes: **Identifying features when installed:**

In addition to the Porsche logo, a part number is shown on the main mufflers and front muffler.

	USA	
Main muffler, left	—	
Main muffler, right	—	
Front muffler	991.111.437.07	

- Tools:
- 9818 - PIWIS Tester II**
  - T10118 - Assembly tool**
  - P300 - Socket-wrench insert**

Work Procedure: 1 Preparatory work.

1.1 Connect a battery charger. ⇒ *Workshop Manual '2X00IN Battery trickle charging'*



**Moving components**

- **Danger of limbs being trapped or severed**
- ⇒ **Do not reach into the danger area.**
- ⇒ **Secure the system to prevent it from being activated accidentally.**
- ⇒ **Keep third parties away from the danger area.**

1.2 Extend the rear spoiler manually using the rocker switch in the passenger compartment.

1.3 Align the support plates of the lifting platform with the jacking points and raise the vehicle. ⇒ *Workshop Manual '4X00IN Lifting the vehicle'*

1.4 Remove the following components in the rear area.

- 1.4.1 Remove engine-compartment blower. ⇒ *Workshop Manual '198119 Removing and installing engine-compartment blower'*
- 1.4.2 Remove air guide. ⇒ *Workshop Manual '243619 Removing and installing air guide'*
- 1.4.3 Remove rear spoiler. ⇒ *Workshop Manual '66581905 Removing and installing rear spoiler'*

 **CAUTION****Hot components**

- Risk of burns
- ⇒ Let hot components cool down.
- ⇒ Wear personal protective gear.

- 1.5 Remove tailpipe covers. ⇒ *Workshop Manual '263519 Removing and installing tailpipe cover'*
- 1.6 Remove front muffler. ⇒ *Workshop Manual '262519 Removing and installing front silencer'*

 **CAUTION****Risk of damage to lines and/or hoses (vacuum)**

- due to incorrect routing.
- ⇒ Maintain a sufficient distance from components exposed to high temperatures while driving.
- ⇒ Avoid making tight bends.

- 2 Route vacuum lines in the engine compartment.

**Information**

Two change-over valves are installed next to each other on the 3.8-liter engine as standard. The change-over valve (Figure 8 -**arrow**-) is responsible for controlling the standard exhaust

system or the sports exhaust system. The change-over valves are located under the DME control unit. Figure shows the change-over valves without fresh air supply.

2.1 Overview of change-over valves.

- 1 – Change-over valve
- 2 – Change-over valve for sports exhaust system

2.2 Remove heat shield on the engine carrier. ⇒ *Workshop Manual '261419 Removing and installing heat shield on engine carrier'*

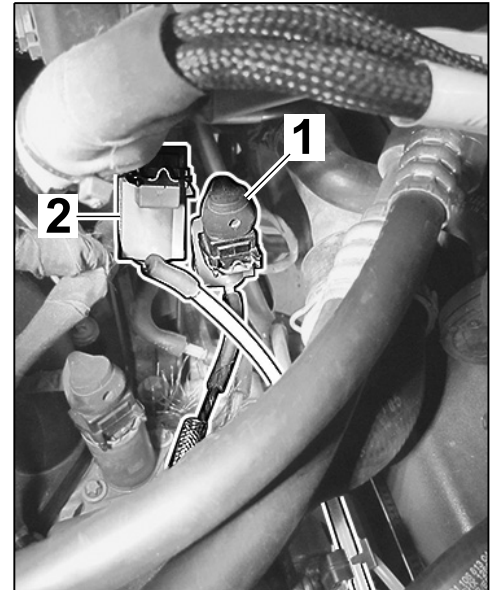


Figure 8

2.3 **Only** for vehicles without the bore ⇒ *Figure 9 -1-*.

Drill out the bore in the heat shield on the engine carrier.



Figure 9

- 2.3.1 Drill the bore hole on the heat shield on the engine carrier according to the dimensions shown in  $\Rightarrow$  *Figure 10*.

- A** - 11.5 mm  
**B** - 21.4 mm  
**C** - Diameter: 7 mm + 0.2

- 2.3.2 Drill a hole in the heat shield on the engine carrier.

- 2.3.3 De-burr the bore.

- 2.4 Remove standard vacuum lines.

- 2.4.1 Pull standard vacuum line  $\Rightarrow$  *Figure 11-3-* off the change-over valve (flap control)  $\Rightarrow$  *Figure 11-arrow-*.

- 1** - DME control unit  
**2** - Change-over valve (flap control)

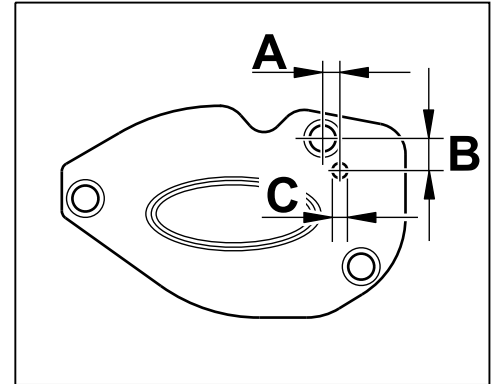


Figure 10

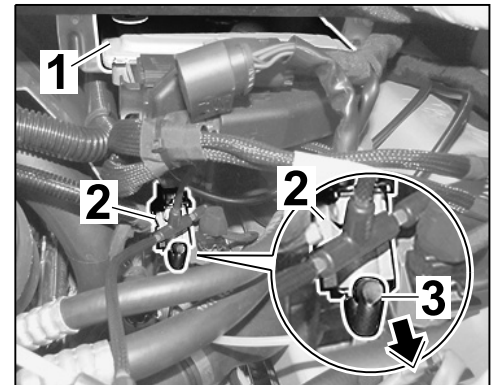


Figure 11

- 2.4.2 Pull standard vacuum line  $\Rightarrow$  *Figure 12-1-* out of the engine carrier  $\Rightarrow$  *Figure 12-2-*.

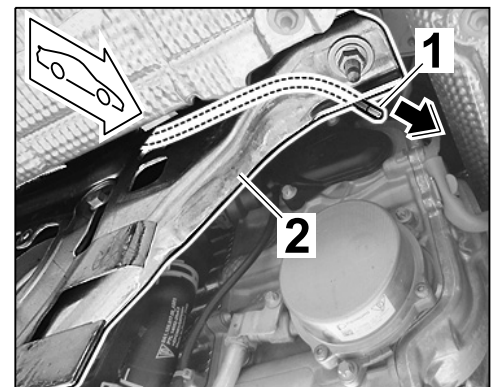


Figure 12

2.5 Assemble vacuum lines (heat shield area).

2.5.1 Cut a 420-mm length off the supplied Tekalan line.



**Information**

Insert vacuum line at least 10 mm into the steel flexi-pipe.

2.5.2 Fit 190-mm steel flexi-pipe ⇒ *Figure 13-3-* and 420-mm Tekalan line ⇒ *Figure 13-4-* together.

2.5.3 Fit holder ⇒ *Figure 13-1-* to the heat shield on the engine carrier ⇒ *Figure 13-2-*.

2.5.4 Slide steel flexi-pipe onto the holder.

2.5.5 Lock single-lug clips ⇒ *Figure 13-5-*.

2.5.6 Pull connecting piece ⇒ *Figure 14-1-* off the standard vacuum line and fit it on the 420-mm Tekalan line ⇒ *Figure 14-2-*.

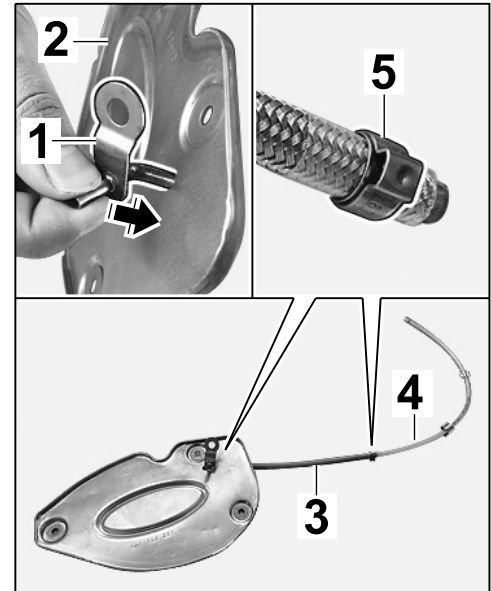


Figure 13

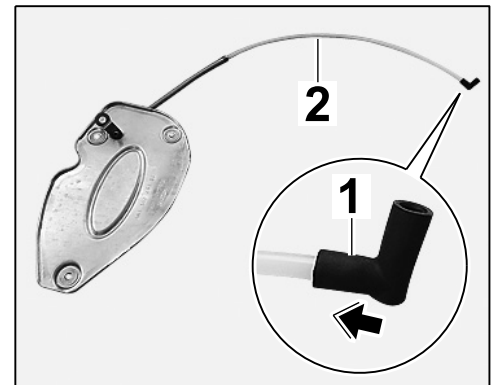


Figure 14

2.6 Install heat shield on engine carrier ⇒ *Figure 15-1-*. ⇒ *Workshop Manual '261419 Removing and installing heat shield on engine carrier'*

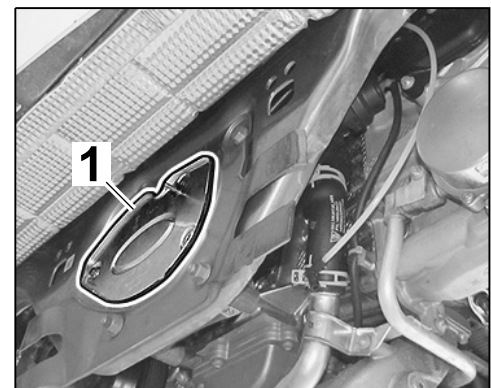
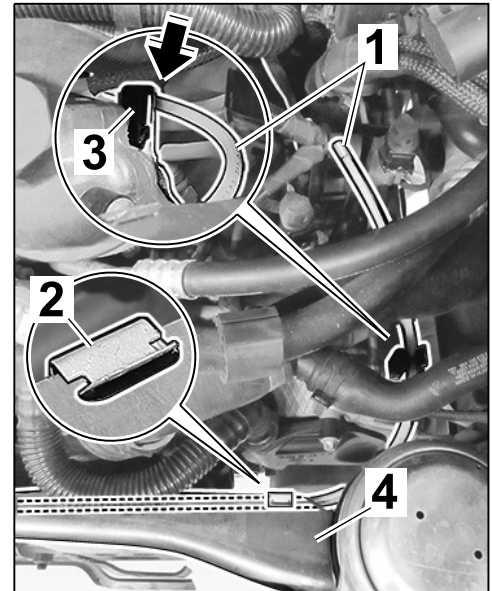


Figure 15

2.7 Connect vacuum line (420-mm Tekalan line)  
⇒ *Figure 16-1-* to the change-over valve (flap control).

2.7.1 Clip 420-mm Tekalan line into the  
standard fixing clip ⇒ *Figure 16-2-*  
on the engine carrier ⇒ *Figure 16*  
*-4-*.

2.7.2 Fit 420-mm Tekalan line into holder  
⇒ *Figure 16-3-*.

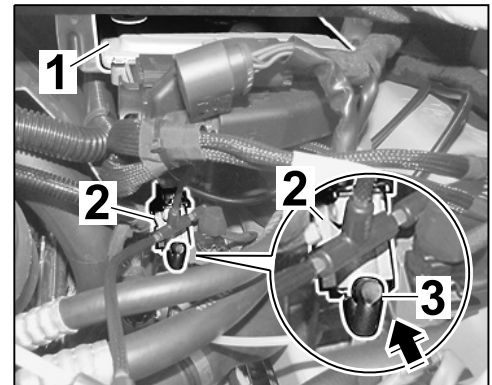


*Figure 16*

2.7.3 Fit connecting piece ⇒ *Figure 17*  
*-3-* on the standard change-over  
valve (flap control) ⇒ *Figure 17*  
*-arrow-*.

- 1 – DME control unit
- 2 – Change-over valve (flap control)

3 Install sports exhaust system.



*Figure 17*

3.1 Fit 80-mm steel flexi-pipe ⇒ *Figure 18-1*- on the connections between the vacuum units.

Lock single-lug clips ⇒ *Figure 18-2*-.



### Information

- Apply a light coating of high-temperature grease (e.g. Optimoly HT, Part No. 000.043.004.00) on the clamp or pipe adapter before installation.

3.2

Install front muffler. See also ⇒ *Workshop Manual '262519 Removing and installing front silencer'*

3.2.1 Fit new metal seal on the exhaust manifold (three-hole flange) at the left and right.

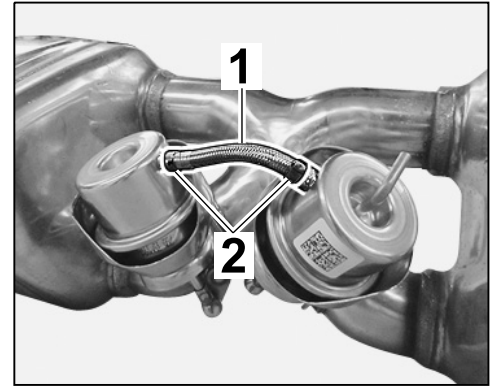
3.2.2 Fit new clamping sleeves on the main silencers at the left and right.

3.2.3 Fit the main mufflers on the exhaust manifold (three-hole flange) with the help of another person. Slide the restraining straps over the holder on the engine carrier. Position strut for main silencer.

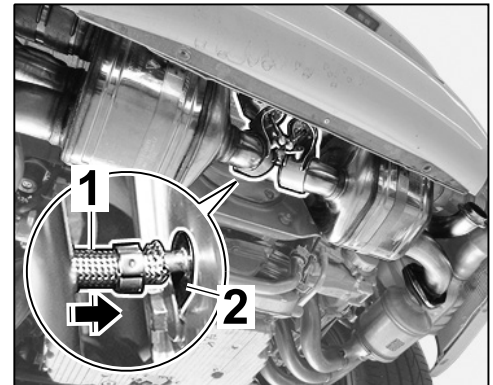
3.2.4 Fit steel flexi-pipe ⇒ *Figure 19-1*- on holder ⇒ *Figure 19-2*-.

3.2.5 Align the front muffler and tighten cheese head bolts on the restraining straps.

**Tightening torque 18 Nm (13 ftlb.)**

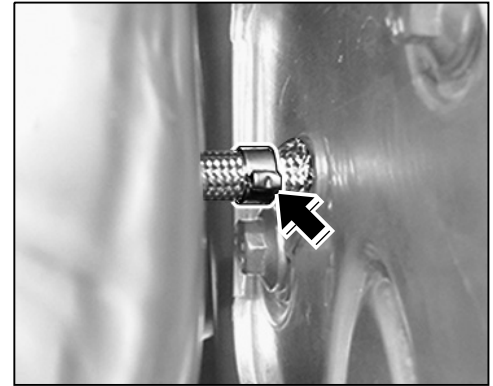


*Figure 18*



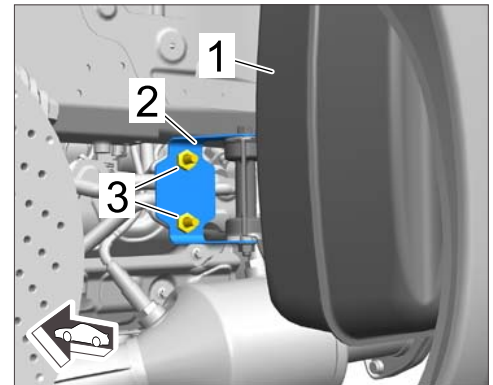
*Figure 19*

- 3.2.6 Lock single-lug clip ⇒ *Figure 20*  
-arrow-.



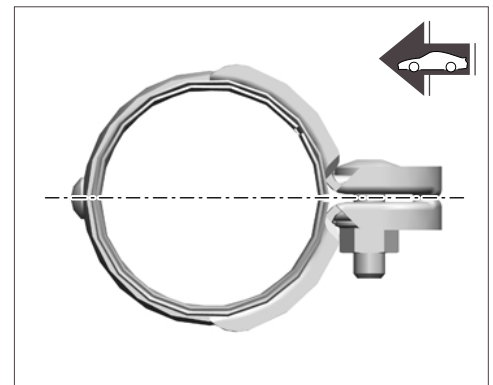
*Figure 20*

- 3.3 Position main muffler at the left ⇒ *Figure 23*  
-1- on the main muffler holder at the front ⇒ *Figure 23-2-* and secure with two new M8 collar nuts ⇒ *Figure 23-3-*.



*Figure 23*

- 3.4 Connect main muffler to the front muffler using the clamp. Fit and tighten M8 collar nut.  
Check installation position of clamp!



*Figure 24*

- 3.5 Fit the main muffler strut on the exhaust manifold (three-hole flange) and secure with three new hexagon nuts ⇒ *Figure 26-1-*.
- 3.6 Tighten threaded joints on the main muffler at the left.
  - 3.6.1 Tighten M8 collar nuts on the front holder (rear wheel housing).  
**Tightening torque 23 Nm (17 ftlb.)**
  - 3.6.2 Tighten M8 hexagon nuts on the three-hole flanges on the exhaust manifold.  
**Tightening torque 23 Nm (17 ftlb.)**
  - 3.6.3 Tighten M8 collar nuts on the clamps.  
**Tightening torque 23 Nm (17 ftlb.)**

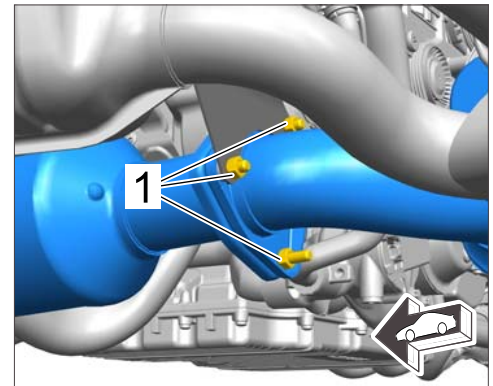


Figure 25

- 3.7 Install tailpipe covers. ⇒ *Workshop Manual '263519 Removing and installing tailpipe cover'*
- 4 Concluding work.
  - 4.1 Lower the vehicle and swivel support plates of the lifting platform aside. ⇒ *Workshop Manual '4X00IN Lifting the vehicle'*
  - 4.2 Install the following parts in the rear area.
    - 4.2.1 Install rear spoiler. ⇒ *Workshop Manual '66581905 Removing and installing rear spoiler'*
    - 4.2.2 Install air guide. ⇒ *Workshop Manual '243619 Removing and installing air guide'*
    - 4.2.3 Install engine-compartment blower. ⇒ *Workshop Manual '198119 Removing and installing engine-compartment blower'*

**⚠ WARNING**

**Moving components**

- **Danger of limbs being trapped or severed**
- ⇒ **Do not reach into the danger area.**
- ⇒ **Secure the system to prevent it from being activated accidentally.**
- ⇒ **Keep third parties away from the danger area.**

- 4.3 Retract the rear spoiler manually using the rocker switch in the passenger compartment.
- 4.4 Convert switch console.

- 4.4.1 Remove switch console. ⇒ *Workshop Manual '962719 Removing and installing switch console'*



#### Information

The switch console consists of a total of 16 buttons, 10 light guides and 10 trims. Each half can be used for the left or right row of the main body.

- 4.4.2 Assemble new switch console in accordance with the new vehicle equipment.

Fit light guide at the correct side ⇒  
*Figure 26-1-* in the main body ⇒  
*Figure 26-arrow-*.

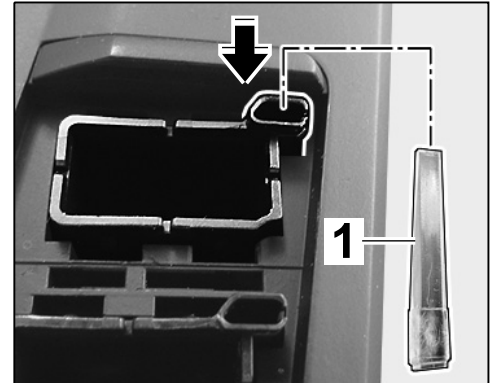


Figure 26

Fit trim ⇒ *Figure 27-1-* underneath  
the button in the main body ⇒  
*Figure 27-arrows-*.

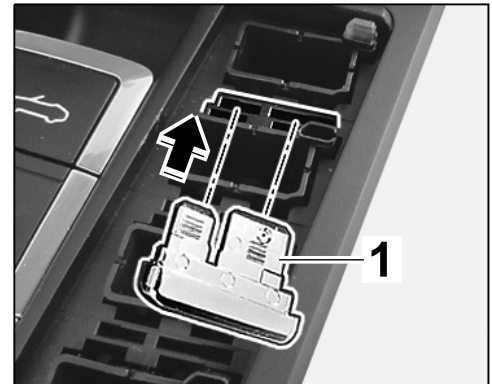


Figure 27

Position button ⇒ *Figure 28-1-* and clip it into the main body ⇒ *Figure 28-arrow-*.

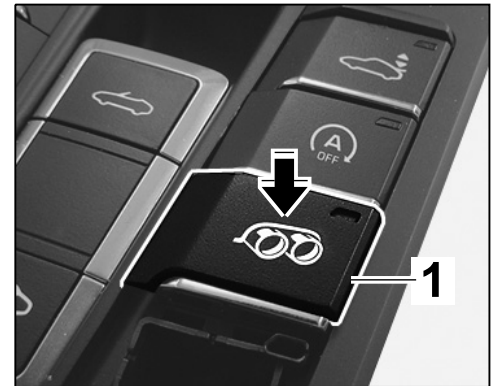
4.4.3 Install switch console. ⇒ *Workshop Manual '962719 Removing and installing switch console'*

5 Code the sports exhaust system.



**Information**

The sports exhaust system button can only be coded on the right-hand side of the switch console.



*Figure 28*

5.1 Code keypad assignment. ⇒ *Workshop Manual '962755 Replacing switch console'*.

5.2 Maintenance of vehicle data

5.2.1 **Select Additional menu** by pressing •F7” .

5.2.2 Select the **Maintenance of vehicle data** function. Press •F12” until **M numbers** appears in the Value group column.

5.2.3 Select **176 - Sports exhaust system** in the Coding value column. When you touch the Installed cell, a tick appears.

5.2.4 Save the values by pressing •F8” . Wait until the message **Modified values have been buffered** appears.

5.2.5 Press •F12” until •F8” can be activated.

5.2.6 Press •F8” to write values. Wait until the message **Generation of vehicle data is complete** appears.

5.2.7 Press •F12” to switch to Log management. Open the log by pressing •F10” and check that vehicle equipment **176 Sports exhaust system** is displayed.

5.3 Adapt coding.

5.3.1 Press •F11” to return to the list of control units. Select all control units.

5.3.2 Switch to the **Codings/adaptations** menu. Select **Automatic coding**. Press •F12” to continue. Wait until the message **Coding has been completed successfully** appears. Press •F12” to continue.

5.4 Once coding is complete, read out the fault memories of all systems, work through any existing faults and erase the fault memories. ⇒ *Workshop Manual '033500 Fault memory for on-board diagnosis'*

## 5.5 Carry out "Sports exhaust system" function test.

The exhaust flaps open when you press the "Twin tailpipe" button. The noise of the exhaust motor can be heard.

5.6 Disconnect battery charger. ⇒ *Workshop Manual '2X00IN Battery trickle charging'*

26013100:	Sports exhaust system installed	Labor time: <b>310 TU</b>
	Includes: Sports exhaust system, 3.8 l (RoW/USA): Removing and installing front silencer and strip for switches, coding strip for switches and sports exhaust system.	
26013103:	Sports exhaust system installed	Labor time: <b>360 TU</b>
	Includes: Sports exhaust system, 3.8 l (China, Japan, PAP): Removing and installing main mufflers, front silencer and strip for switches, coding strip for switches and sports exhaust system.	

**Important Notice:** Technical Bulletins issued by Porsche Cars North America, Inc. are intended only for use by professional automotive technicians who have attended Porsche service training courses. They are written to inform those technicians of conditions that may occur on some Porsche vehicles, or to provide information that could assist in the proper servicing of a vehicle. Porsche special tools may be necessary in order to perform certain operations identified in these bulletins. Use of tools and procedures other than those Porsche recommends in these bulletins may be detrimental to the safe operation of your vehicle, and may endanger the people working on it. Properly trained Porsche technicians have the equipment, tools, safety instructions, and know-how to do the job properly and safely. If a particular condition is described, do not assume that the bulletin applies to your vehicle, or that your vehicle will have that condition. See your authorized Porsche Dealer for the latest information about whether a particular technical bulletin applies to your vehicle. Part numbers listed in these bulletins are for reference only. Always check with your authorized Porsche dealer to verify the current and correct part numbers. The work procedures updated electronically in the Porsche PIWIS diagnostic and testing device take precedence and, in the event of a discrepancy, the work procedures in the PIWIS Tester are the ones that must be followed.

© Porsche Cars North America, Inc.

Dealership	Service Manager	Shop Foreman	Service Technician				
Distribution							
Routing	Asst. Manager	Warranty Admin.	Service Technician				

Dr. Ing. h.c. F. Porsche AG is the owner of numerous trademarks, both registered and unregistered, including without limitation the Porsche Crest®, Porsche®, Boxster®, Carrera®, Cayenne®, Cayman®, Macan®, Panamera®, Speedster®, Spyder®, 918 Spyder®, Tiptronic®, VarioCam®, PCM®, PDK®, 911®, RS®, 4S®, FOUR, UNCOMPROMISED®, and the model numbers and the distinctive shapes of the Porsche automobiles such as, the federally registered 911 and Boxster automobiles. The third party trademarks contained herein are the properties of their respective owners. Porsche Cars North America, Inc. believes the specifications to be correct at the time of printing. Specifications, performance standards, standard equipment, options, and other elements shown are subject to change without notice. Some options may be unavailable when a car is built. Some vehicles may be shown with non-U.S. equipment. The information contained herein is for internal authorized Porsche dealer use only and cannot be copied or distributed. Porsche recommends seat belt usage and observance of traffic laws at all times.

Printed in the USA